

Technical release

This is not a release for the PSI System itself. The entire system has not been tested by Valx. Therefore the PSI System is not offered by Valx

The release covers the necessary changes to the Valx axle and the hubodometer hub cap in the context of retrofitting a trailer fitted with Valx axles to accommodate the PSI System.

Following changes need to be done to the Valx axle:

1-Drill a hole from 8,6 mm in the axle beam to make the air pressure connection possible.

After drilling this hole a 1/8"BSPT (GAS) thread has to be cut in this hole.

The drilled hole has to be on the center line from the axle beam, horizontal and between the air suspension and the brake. See the red arrow in the picture below.

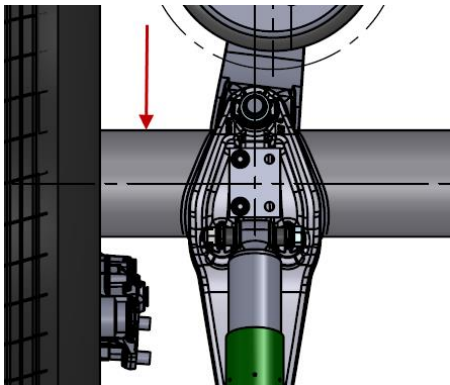

2-The Valx plug has to be removed from the axle spindle and needs to be replaced by a special designed PSI plug for the Valx axle beam.

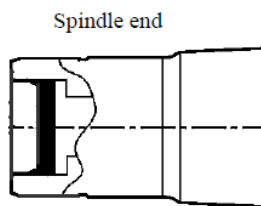

3-The Valx hub cap has to be replaced by a special (PSI) adapted Valx hubodometer hub cap (delivered by PSI). When replacing the hub cap a new O-ring has to be used in the hub. (see valx instructions for hub cap mounting in the manual on www.valx.eu)

The hub cap with PSI system needs an extra fixation by 2 plates holding the hubcap into the hub. (delivered by PSI).

The mounting and sealing from the PSI parts on the changed hubodometer hub cap remain the responsibility from PSI.

PSI System on Valx axle

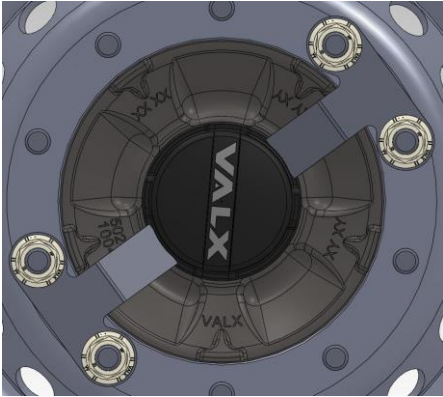

Failure to comply with these instructions or use components not supplied by PSI will invalidate any warranty.

Date:	4-5-2015
Name:	G. Colen
Version:	VF-TA-0003-B